

# Simple Installation Guide

The machine should be installed correctly by professional technicians according to the manufacturer's specifications and requirements.

**If the unit is installed incorrectly and as a result is not operating correctly it is the responsibility of the purchaser / installer. The supplier accepts no responsibility for faulty or incorrect installations.**

## Guide to the customer

- The customer should provide a suitable power supply source; the voltage should be in the range of 90-110% of the rated voltage of the system.
- The power supply circuit should have MCB leakage protection. The power supply capacity should be no less than 13 Amps.
- You should use an independent circuit and a suitably earthed socket matching with the plug of air-conditioner.
- The wiring must be installed by qualified electrician according to the latest electrical safety requirements.
- The air-conditioner must be well earthed; the switch of the main power of air-conditioner must be reliably earthed, there should be an isolator on the outdoor unit.
- The power supply should be connected by a qualified electrician.

## Installation Steps.

---

1. Select the most suitable installation position.
2. Installing the air-conditioner.
3. Connecting the pipes.
4. Expelling the air in the pipes and the indoor unit.
5. Electrical Connection.
6. Testing.

# Installation Instructions

## 1 Selection of the installation position

### Indoor Unit

- Ensure there is no heating or steam source nearby.
- No obstacles are in the way of the pipes/wiring.
- There is good air circulation.
- Convenient to adopt measures to reduce noises.
- Don't install them near the doorway.
- Make sure you have the distance specified in the picture between the ceiling, wall, furniture and other obstacles.
- 2 meters high above the floor (for best performance).

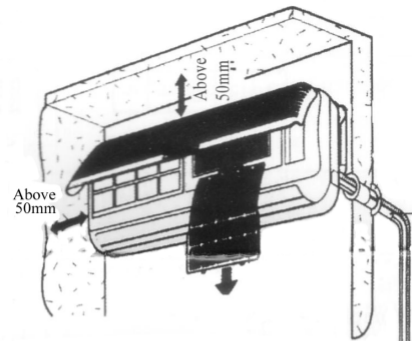

### Outdoor Unit

- If you put up a canopy to protect it from rain and sun, pay attention not to cause any obstacle for dispersion of heat from the condenser.
- Don't keep animals or plants near the installation location as the hot air from the outdoor unit will affect them.
- Make sure you have the distance specified in the picture between ceiling, wall and other obstacles.
- Keep away from heat sources or flammable gases.
- The installation base and supporting frame should be strong and secure. The machine should be on a level surface.

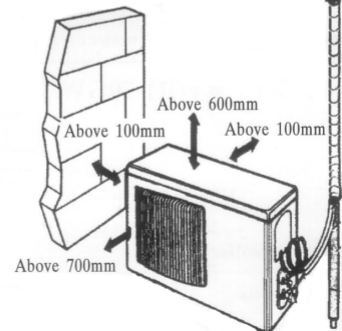

## 2a Installation of the Outdoor Unit

- The outdoor unit must be firmly fixed to avoid falling over in strong winds.
- Install on a cement base as in the drawing or use our wall brackets.
- If it is installed near coastal areas or high above the ground where strong winds are likely, the unit should be installed against the wall to ensure the normal operation of the fan and a wind blocking construction should be made.
- If it is an overhanging installation, the structure of the mounting wall should be made of a solid, cement or materials with equivalent strength, and of sufficient support capacity. Otherwise, measures such as reinforcement, support or vibration damping should be adopted.

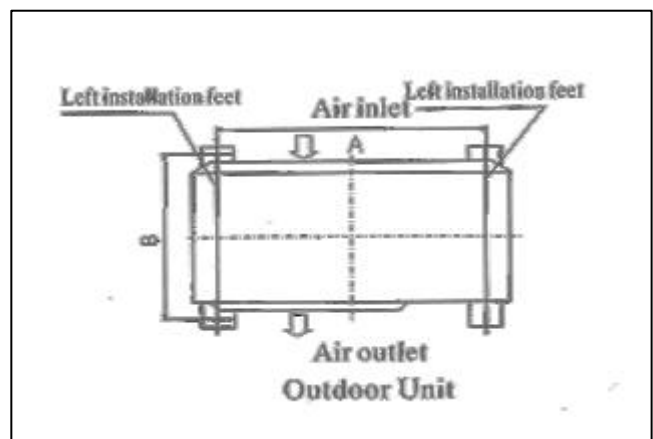

## 2b Installation of the Indoor Unit

PLEASE NOTE: when removing the *first* copper end plug pipe from the back of the indoor unit (the short pieces of pipe with crimped and soldered ends) you should hear a hiss of air escaping, this is completely normal, they are pressurised and tested for leaks at the factory. If you do not hear any air escape as the first of These pipes are undone, please contact us as your unit may be faulty. Otherwise proceed.

- First check the wall and make sure that it is firm and secure. Use four Philips screws and suitable wall plugs to fasten the installation bracket onto the wall. Keep it level and flat to the wall otherwise it might cause water drips when air-conditioner is running in cooling operation. Make sure the top is well fixed, or the bracket may flex.
- Drill a 65mm diameter pipe hole at the left lower or right lower side of the installation board. The hole should slant downward slightly.
- Hang the indoor unit on the bracket and make sure the unit is in the middle of the bracket. Push the machine towards the left lower and right lower side of the installation bracket until the hangers enter tightly into the groove (and it produces a “click” sound)

## 2c Check the water discharge

*Only attempt this procedure if you are confident you will be able to remove/replace the front frame without damaging the clips at the top of the unit.*

- Take off the front frame from the unit cover. Take off the front frame for maintenance according to the following steps:
- As shown in the picture on the right, take off two covers from the front frame and then unfasten two fixture screws, and 1 screw by central LED display.
- Pull the front frame towards you and take it off. To put the front frame back, reverse the steps. You should check whether the front frame is firmly fixed into the fixture groove on the top.
- To check the water discharge:-  
Pour a cup of water into groove.  
Check whether the water flows through the water discharge hole correctly.

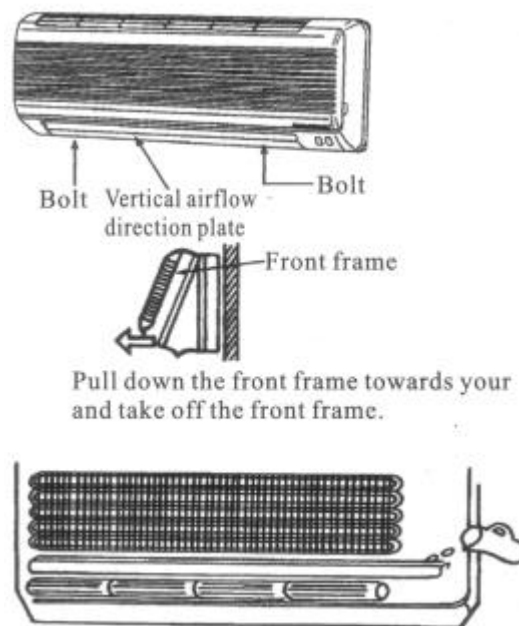

### 3a Pipe Connection – Special Care Required!

- Connect the pipes to the unit: Apply a few drops of 3 in 1 oil to each face first (no additives) place taper to the centre of the pipe and fasten the connection screw carefully at first by hand and then with 2 spanners that fit correctly until it is tightly fastened. The pipes must be very tight to avoid leaks, but do not damage the fittings. The fastening direction is shown in the picture. (Clockwise)
- Repeat the same process for both pipes.

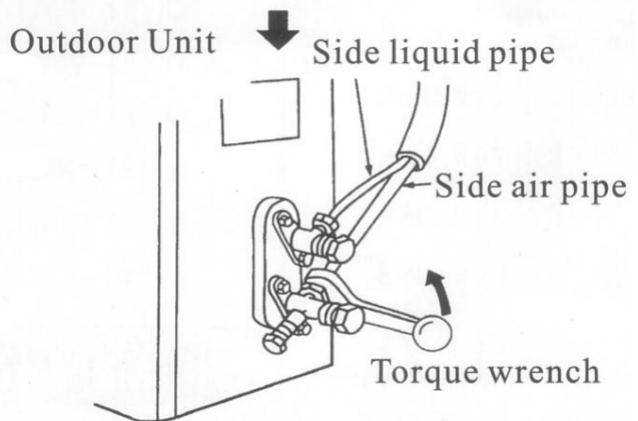
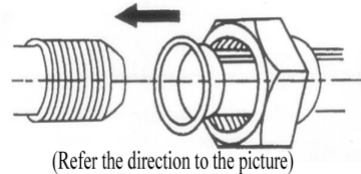
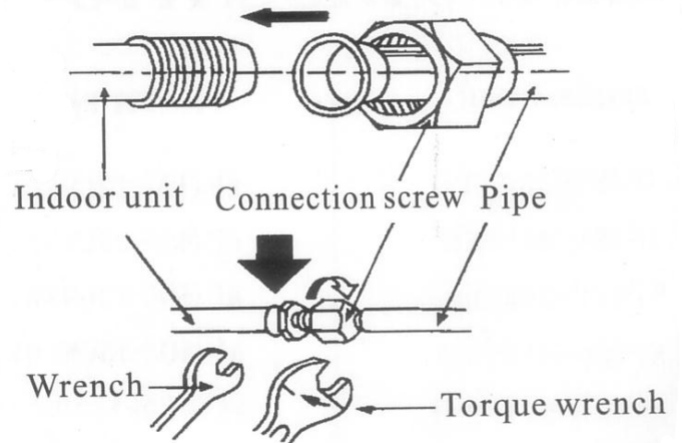

### 3b Fixing the pipes

- Wrap up all pipes, water discharge tube and connection wires from top to bottom with insulating material/foam.
- Cover the connection parts with insulation material and fix them with two plastic rings or cable ties.
- Wrap up the pipes with tape alongside the wall and fix them to the wall with clips. These steps are usually adopted when outdoor unit is installed below the indoor unit.
- In case that you want to have an additional water discharge pipe, the end of pipe should be within a certain distance from the floor (to prevent water from draining back into the pipe). Fix it onto the wall so it won't be swayed by wind.
- Wrap the pipes and connection wire well from bottom to top.
- Wrap up the pipes that are grouped together in the way shown in the picture as it may prevent water from entering the room.
- Use clips or other fixings to fasten the pipes to the walls.

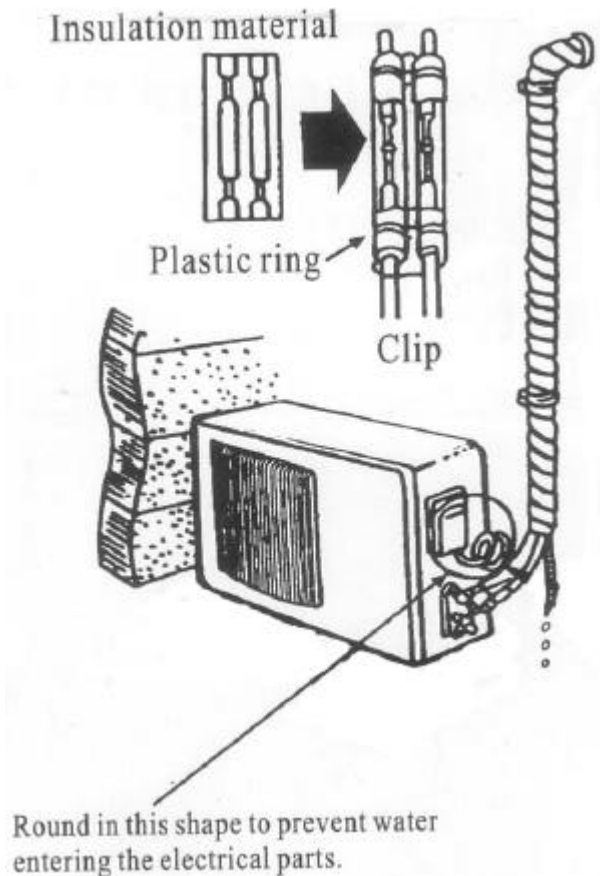

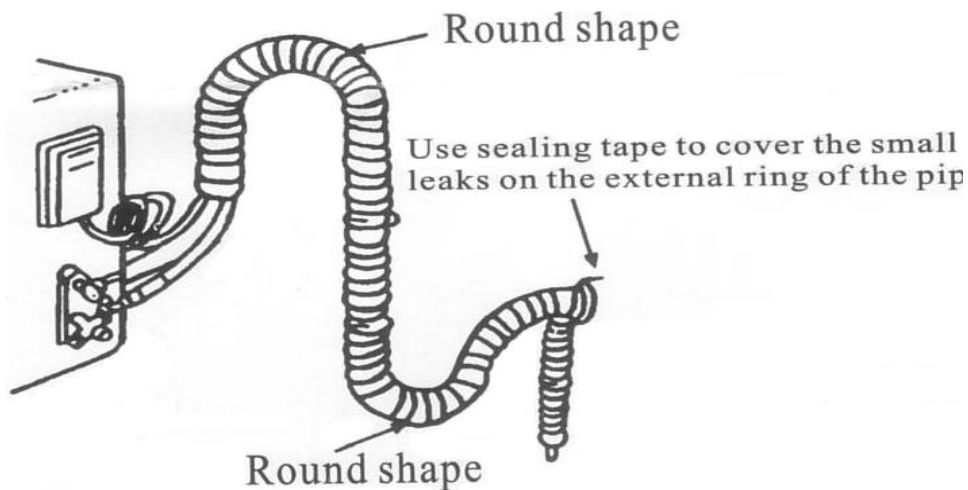

**4 Expelling the air in the pipes and the indoor unit – Pay attention to exact timings!**

You must expel all the air from the system: moisture or damp air in the refrigerating system will cause problems with the compressor.

Please use a stop watch or digital watch to accurately time procedures c) and e) below.

- a) Take off the cover from the stop valve and T-branch valve.
- b) Take off the auxiliary cover from the T-branch valve.
- c) Turn the stop valve rod (TOP VALVE - see diagram) anti clock-wise to an angle of 90 degrees (QUARTER OF A TURN), keep it open for 7 - 8 seconds and CLOSE the valve.
- d) Check whether there is any air leakage at all connection parts of pipes using soapy water to see if any air bubbles form on the pipe joints, tighten if necessary, and recheck. Once there are no leaks, you can continue.
- e) Push in the 'tyre inflator' style valve on the T-branch valve (LOWER VALVE) for 4 – 5 seconds using a screwdriver to expel the air. CAUTION: use a long enough implement as the refrigerant gas *may* be VERY COLD (not normally in summer).

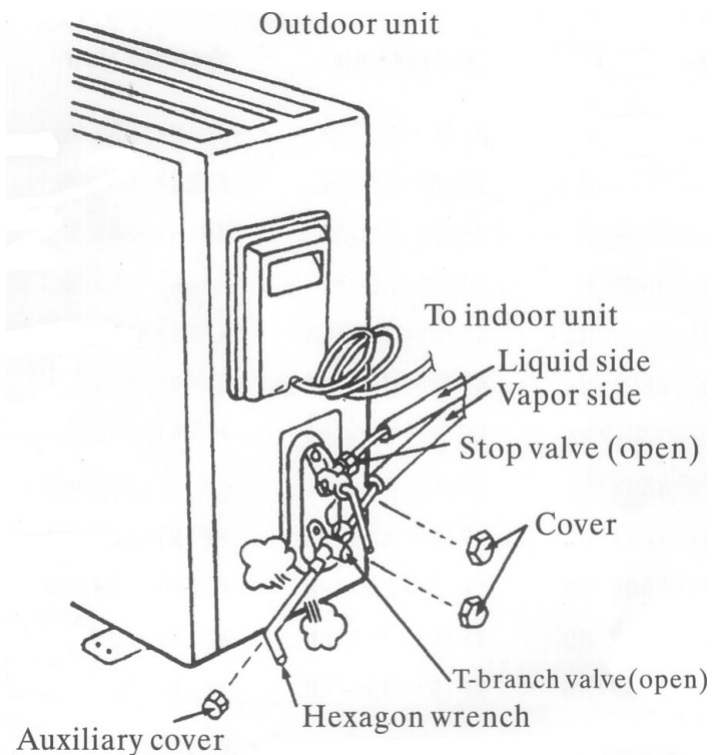

- You may notice a slight oil residue on the tip of the screwdriver, this is normal.
- f) VERY IMPORTANT - Finally, open the stop and T-branch valves with a hexagon wrench (Allen key) fully anti-clockwise until they stop (then back off a quarter turn to avoid seizing) to allow the gas to freely circulate around the system. Then replace the 3 brass covers on the valves.

**Failure to open the 2 valves fully may result in failure of the compressor.**

- g) There must be no leaks, please check all the piping connections parts again. You must test for leaks in all joints; generally, this can be tested with washing up liquid in water. A small flower sprayer is ideal for this.

## 5 Electrical connection

- Unscrew the screws, and take off the control panel cover (handle) from the outdoor unit.
- Using the wire colours and wiring diagram, connect the wires to the signal connection plug at the correct terminal points.

Remarks: see wiring diagram below, yellow and green wire should be connected to connection point with ⊕ (earth) mark.

- Fasten securely the wires to the control panel.
- Screw up the control panel cover to its original place.
- On KFR-51GW/L (18,000BTU) models, you will need to connect the wires to the indoor unit as well. Remove the cover from the right hand side behind the front lift up inspection cover. You can slide the wires in from underneath. Connect as shown in the colours below, matching the terminal numbers between indoor and outdoor units. Note:- if your colours do not match those below, just connect the terminal numbers in parallel, i.e. 1 to 1, 2 to 2, 3 to 3, 4 to 4, earth to earth.

## Hot pump Type

### Outdoor connection point board

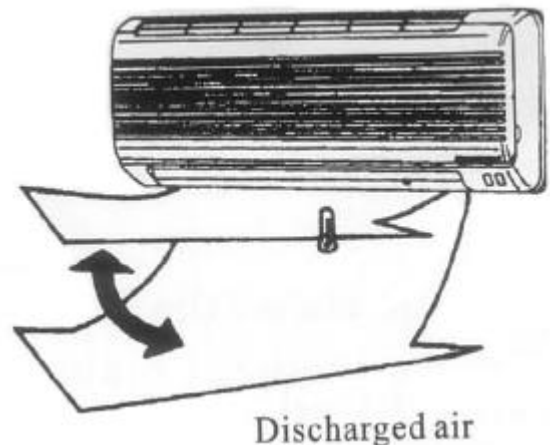
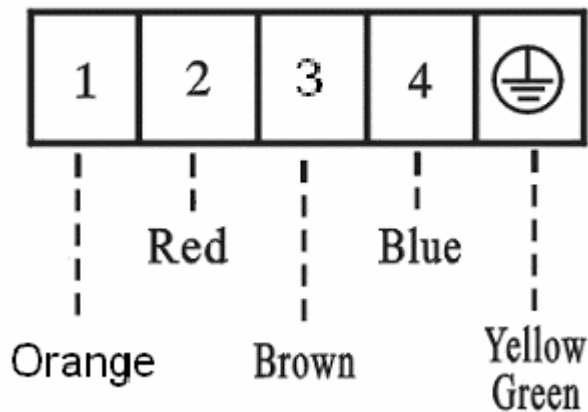

## 6 Test running

- Make sure that the pipes and wires are connected.
- Make sure that both the liquid valve and gas valve on the side of the outdoor unit are COMPLETELY OPEN.
- Connecting the indoor unit to the power source
  - Connect the mains wires to an independent power source socket of the correct rating.
  - Fit batteries in the remote control.
  - When operating for the first time - run the air-conditioner in the cooling operation mode for 30 minutes or longer.
- Performance evaluation
  - Test the outdoor / indoor air temperatures.
  - Make sure that the temperature difference between the outdoor and indoor air is greater than 8°C. The unit may not heat or cool if the selected temperature is not more than 8 degrees difference from the outdoor temperature.

**IMPORTANT - Items to note:**

- Fix the machine firmly; otherwise it will produce noise and vibration.
- If using wall brackets for the outdoor unit, use the rubber insulation blocks provided underneath the feet, between unit and bracket to reduce noise.
- Install the outdoor unit where it will not disturb your neighbours.
- When switching between heating and cooling modes, switch off system for 3 minutes before changing the mode.
- When using heating mode, the indoor unit fan will not operate until sufficient heat has been generated by the outdoor unit, this may take several minutes initially when selecting heating. Please be patient and wait for the fan to operate and blow warm air.

**Electrical connection diagrams:**

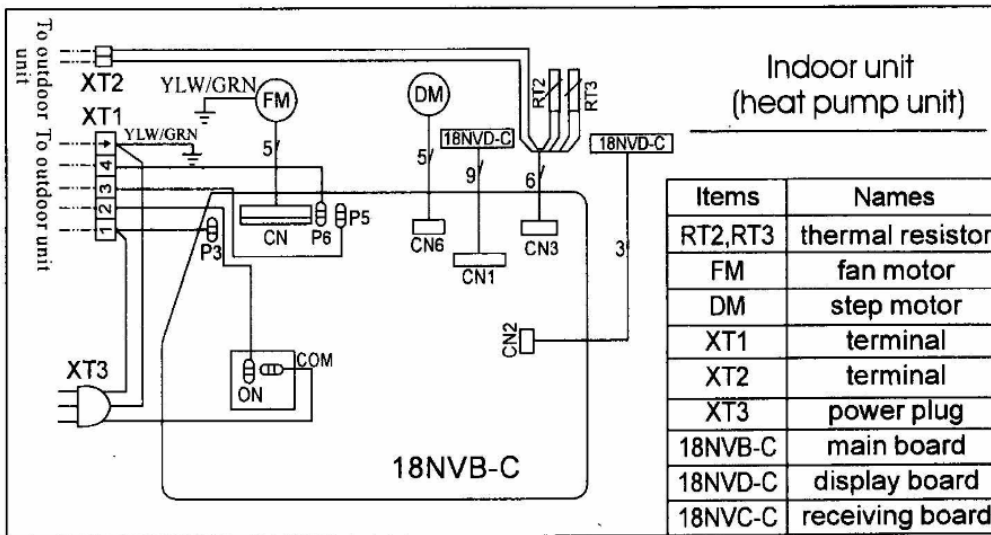

**Wiring of cables to terminal:**

1--blue 2--brown 3--black 4--white 5--yellow/green

Note: Wiring diagram is subject to change.

See the wiring diagram on the unit.

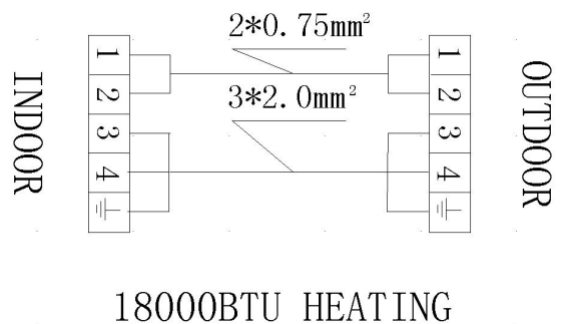
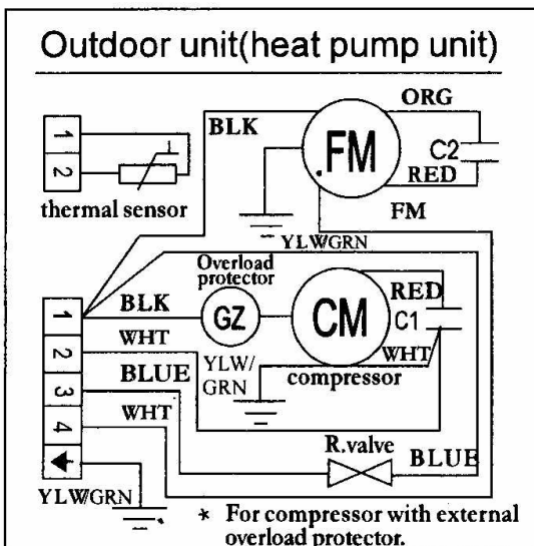

Tel: 0870 3344556

Fax: 0870 3344559

Email: support@airconditioningcentre.co.uk